



3 Pin, Low-Power, μ P Reset Circuits

Pin Configuration SOT-23 (Top View)

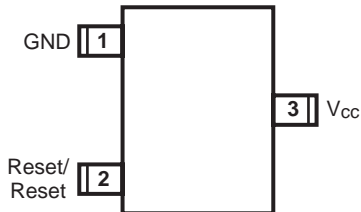
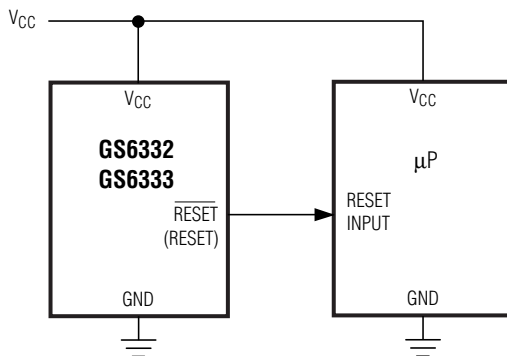

Fig. 1 – Typical Application Diagram



Applications

- Computers
- Critical μ P/ μ C power monitoring
- Battery powered equipment
- Automotive electronics

Description

- The GS6333 and GS6332 are system supervisor circuits designed to monitor V_{CC} in digital systems and provide a reset signal to the host processor when necessary. No external components are required.
- When the processor power supply voltage drops below the reset threshold, the reset output is driven active, in less than $40\mu\text{s}$ (T_{D1}). Reset is maintained active for a time period (T_{D2}), after the V_{CC} rises above the threshold voltage.
- To prevent jitter, the reset threshold voltage has a built-in hysteresis of 0.4% of V_{TH} .
- The GS6333 has an active-low $\overline{\text{reset}}$ output, while the GS6332 has an active-high reset output. Both devices have push/pull output drives.
- The reset signal is guaranteed valid, down to $V_{CC} = 1.0\text{V}$.
- Low supply current of $3\mu\text{A}$ makes these devices well suited for battery powered applications. They are designed to reject fast transients from causing false resets.
- Both devices are available in a space-saving SOT-23 package.

Features

- Tight reset voltage tolerances $\pm 1.8\%$
- Low supply current: $< 3\mu\text{A}$
- Precision monitoring of 1.8V and 2.5V powersupply voltages
- Other threshold voltage options available from 1.5V to 2.5V in approximately 100mV increments
- Three reset active time-out period options: typical 1.5mS, 30mS, 150mS
- $\overline{\text{Reset}}$ output guaranteed down to 1.0V
- V_{CC} transient immunity
- No external components

Ordering Information

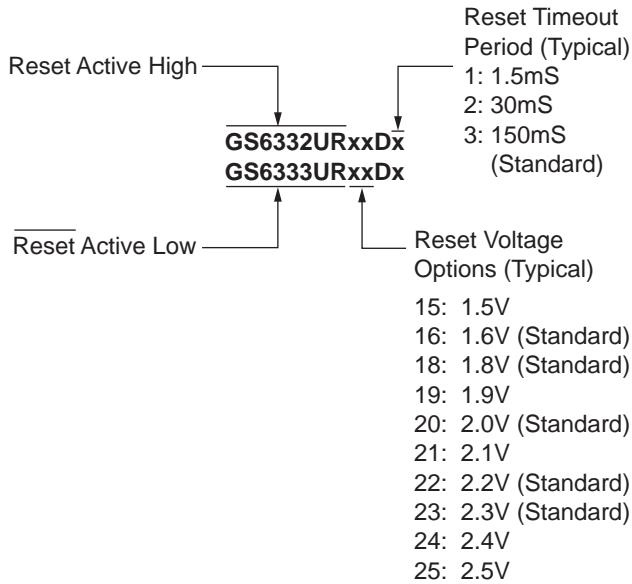

Sample stock is generally available on standard parts. Contact our local sales office for availability of non standard versions (minimum order quantity is 10,000 pcs).

Marking Codes

GS6333		GS6332	
Product No.	Marking	Product No.	Marking
GS6333UR15D1	ADxxx	GS6332UR15D1	BNxxx
GS6333UR15D2	AExxx	GS6332UR15D2	BOxxx
GS6333UR15D3	AGxxx	GS6332UR15D3	BPxxx
GS6333UR16D1	AHxxx	GS6332UR16D1	BRxxx
GS6333UR16D2	AIxxx	GS6332UR16D2	BSxxx
GS6333UR16D3	AKxxx	GS6332UR16D3	BTxxx
GS6333UR18D1	ALxxx	GS6332UR18D1	BVxxx
GS6333UR18D2	AMxxx	GS6332UR18D2	BWxxx
GS6333UR18D3	ANxxx	GS6332UR18D3	BXxxx
GS6333UR19D1	AOxxx	GS6332UR19D1	BYxxx
GS6333UR19D2	APxxx	GS6332UR19D2	BZxxx
GS6333UR19D3	ARxxx	GS6332UR19D3	CAxxx
GS6333UR20D1	ASxxx	GS6332UR20D1	CBxxx
GS6333UR20D2	ATxxx	GS6332UR20D2	CCxxx
GS6333UR20D3	AVxxx	GS6332UR20D3	CDxxx
GS6333UR21D1	AWxxx	GS6332UR21D1	CExxx
GS6333UR21D2	AXxxx	GS6332UR21D2	CGxxx
GS6333UR21D3	AYxxx	GS6332UR21D3	CHxxx
GS6333UR22D1	AZxxx	GS6332UR22D1	CIxxx
GS6333UR22D2	BAxxx	GS6332UR22D2	CKxxx
GS6333UR22D3	BBxxx	GS6332UR22D3	CLxxx
GS6333UR23D1	BCxxx	GS6332UR23D1	CMxxx
GS6333UR23D2	BDxxx	GS6332UR23D2	CNxxx
GS6333UR23D3	BExxx	GS6332UR23D3	COxxx
GS6333UR24D1	BGxxx	GS6332UR24D1	CPxxx
GS6333UR24D2	BHxxx	GS6332UR24D2	CRxxx
GS6333UR24D3	BIxxx	GS6332UR24D3	CSxxx
GS6333UR25D1	BKxxx	GS6332UR25D1	CTxxx
GS6333UR25D2	BLxxx	GS6332UR25D2	CVxxx
GS6333UR25D3	BMxxx	GS6332UR25D3	CWxxx



Absolute Maximum Ratings⁽¹⁾

Parameter	Symbol	Value	Unit
Supply Voltage	V_{CC}	6.0	V
Reset/ $\overline{\text{Reset}}$		-0.3 to ($V_{CC} + 0.3$)	V
Input Current, V_{CC}		20	mA
Output Current, Reset/ $\overline{\text{Reset}}$		20	mA
dV/dT (V_{CC})		100	V/ μ S
Operating Temperature Range	T_A	-40 to +125	$^{\circ}$ C
Storage Temperature Range	T_{stg}	-65 to +150	$^{\circ}$ C
Power Dissipation ($T_A \leq 70^{\circ}$ C) SOT-23 (Derate 4mW/ $^{\circ}$ C above 70 $^{\circ}$ C)	P_D	260	mW

Note: (1) Stresses beyond those listed under "Absolute Maximum Ratings" may cause permanent damage to the device.

Electrical Characteristics $T_A = -40^{\circ}$ C to 125 $^{\circ}$ C unless otherwise noted. Typical values are at $T_A = 25^{\circ}$ C

Parameter	Symbol	Test Conditions	Min	Typ	Max	Unit
V_{CC} Range	V_{RANGE}	$T_A = 25^{\circ}$ C	1	-	5.5	V
		$T_A = -40$ to +85 $^{\circ}$ C	1	-	5.5	
		$T_A = -40$ to +125 $^{\circ}$ C	1.2	-	5.5	
Supply Current (No Load)	I_{CC}	$V_{CC} = 3.0$ V	-	-	7.0	μ A
		$T_A = 25^{\circ}$ C	-	-	3.0	
Reset Threshold	V_{TH}	$T_A = 25^{\circ}$ C	$V_{TH} - 1.8\%$	V_{TH}	$V_{TH} + 1.8\%$	V
		$T_A = -40$ to +125 $^{\circ}$ C	$V_{TH} - 3\%$	V_{TH}	$V_{TH} + 3\%$	
Threshold Hysteresis	$V_{TH\ HIST}$			0.4		$\%V_{TH}$
Reset Output Voltage Low	V_{OL}	GS6332 $V_{CC} > V_{TH}$ GS6333 $V_{CC} < V_{TH}$ $I_{SINK} = 50\mu$ A, $V_{CC} \geq 1.0$ V $I_{SINK} = 500\mu$ A, $V_{CC} \geq 1.8$ V	-	-	0.4 0.3	V
Reset Output Voltage High	V_{OH}	GS6332 $V_{CC} < V_{TH}$ GS6333 $V_{CC} > V_{TH}$ $I_{SOURCE} = 200\mu$ A, $V_{CC} \geq 1.8$ V $I_{SOURCE} = 500\mu$ A, $V_{CC} \geq 2.7$ V	0.8 V_{CC} 0.8 V_{CC}	-	-	V
V_{CC} Falling Reset Delay	T_{D1}	V_{CC} to $V_{TH} - 100$ mV	-	-	40	μ S
Reset Timeout Period	T_{D2}	GS633xUR-D1	0.5	1.5	5	mS
		GS633xUR-D2	15	30	50	
		GS633xUR-D3	80	150	230	

Ratings and Characteristic Curves ($T_A = 25^\circ\text{C}$ unless otherwise noted)

Fig. 2 – Timing Diagram

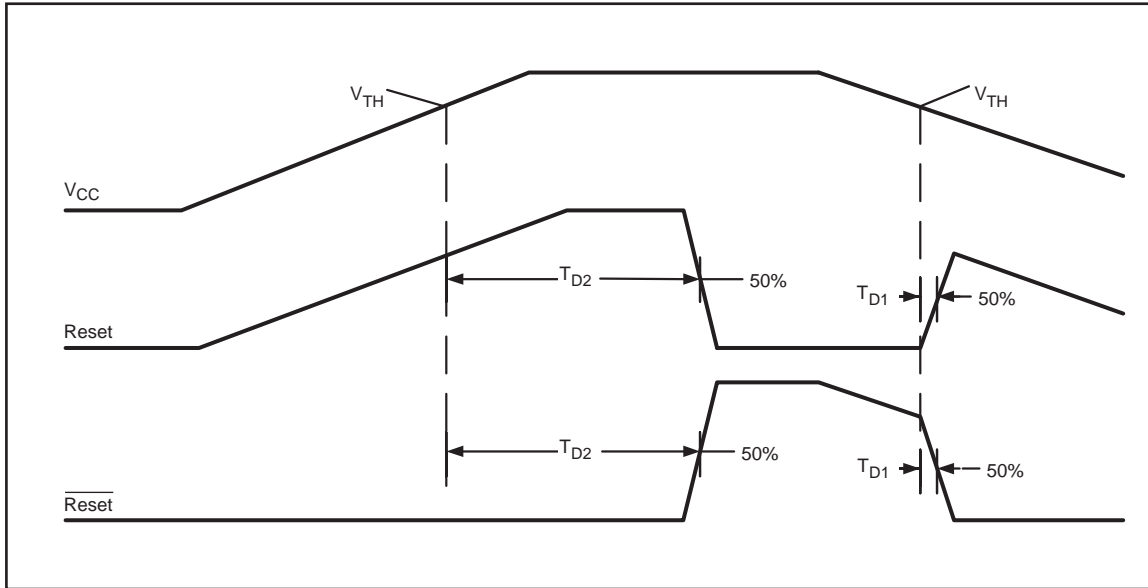

Supply (V_{CC}) Transients

These devices have a certain immunity to fast negative going transients. The graph titled "Transient Rejection" shows the maximum allowable transient amplitude and duration to avoid triggering an unintended reset. As shown in the graph shorter transients can have larger amplitudes without triggering resets.

Fig. 3 – Transient Rejection

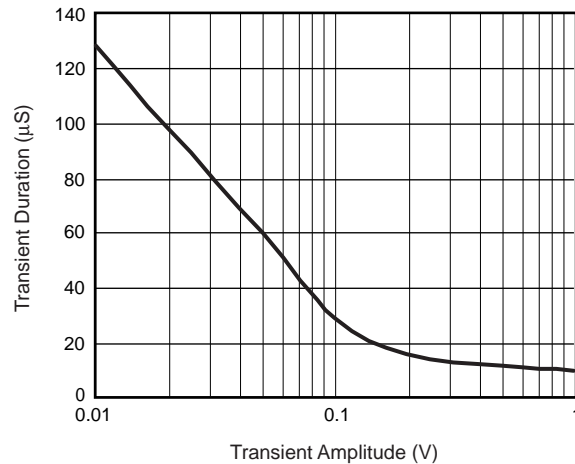

Ratings and Characteristic Curves ($T_A = 25^\circ\text{C}$ unless otherwise noted)

Fig. 4 – Reset Time vs. Temperature

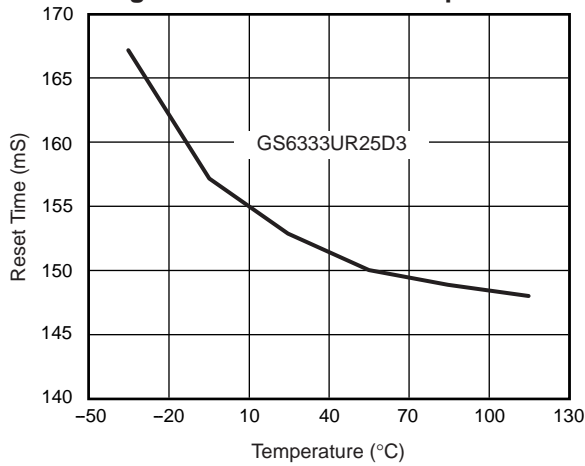

Fig. 5 – I_{CC} vs. Temperature

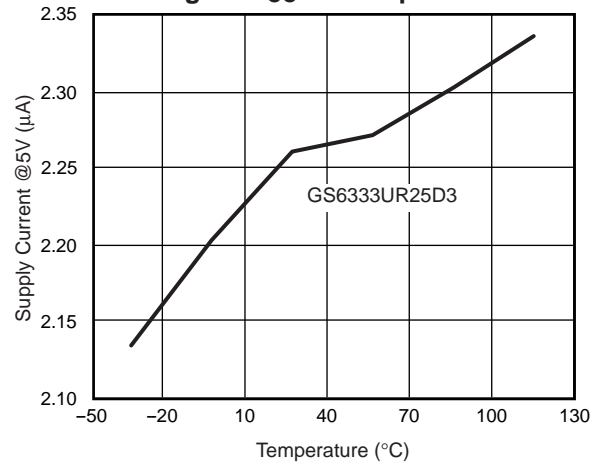

Fig. 6 – Reset V_{th} vs. Temperature

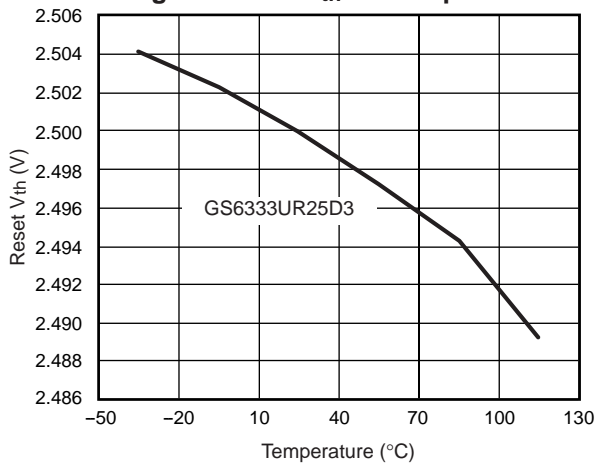

Fig. 7 – I_{CC} vs. V_{CC}

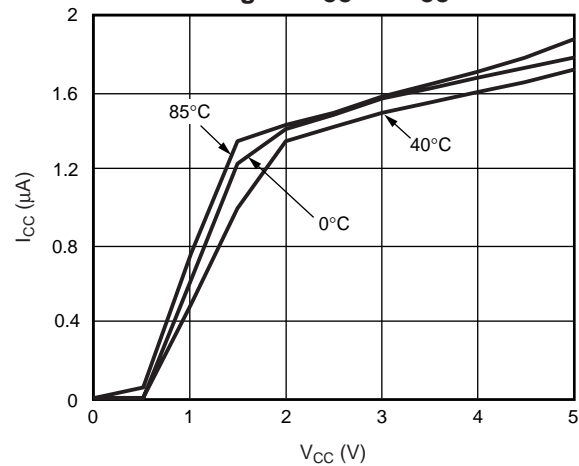
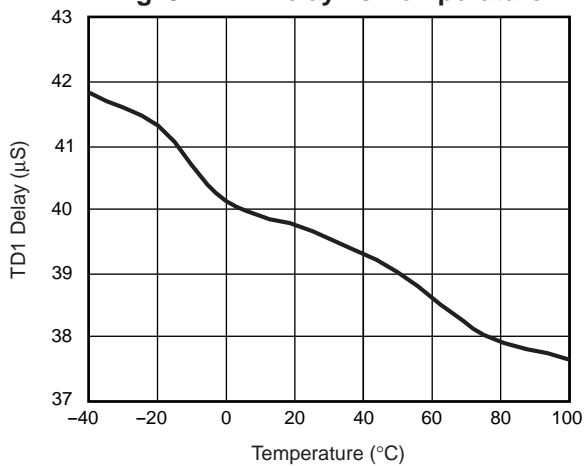

Fig. 8 – TD1 Delay vs. Temperature



Ratingsand CharacteristicCurves ($T_A=25^\circ\text{C}$ unless otherwise noted)

Fig. 9 – Threshold Hysteresis vs. Temperature

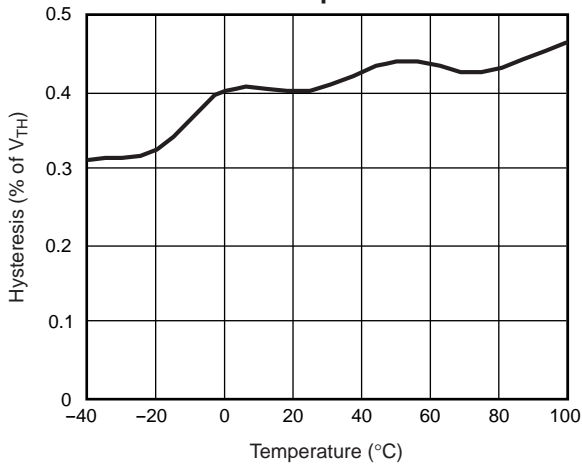
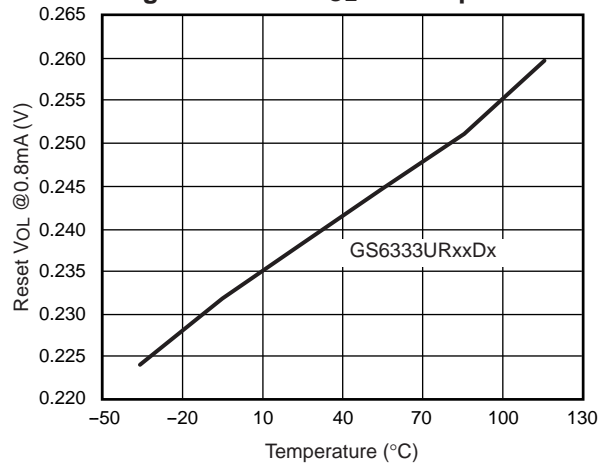
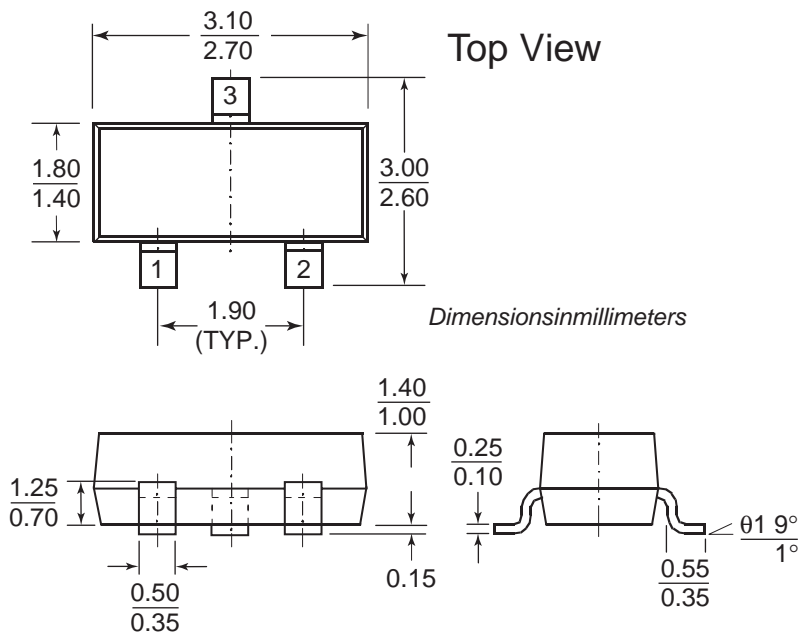

Fig. 10 – Reset V_{OL} vs. Temperature



SOT-23CaseOutline



Mounting Pad Layout

